

## 30cm Domino Electric BBQ

Code EMJBQ30SX Stainless Steel



### THE euro MILAN DOMINO BUILT-IN BBQ

Is elegantly designed to give your kitchen a contemporary look, but more importantly many variations in cooking. The food is cooked slowly over low direct heat & is flavoured by the smoking process. Made of high quality stainless steel & convenient front control knobs, it is durable, easy to operate & maintain.

### FEATURES

- Stainless Steel
- Cast iron removable grid
- 12 position temperature control
- Lava stones creating charcoal style cooking
- Drip pan
- Front knob control operation
- On / Off indicator light
- Movable heating element for easy cleaning
- Made in Italy

### LAVA STONES & DRIP PAN

The function of the lava stone contained in the drip pan is to absorb drippings of oil or fat that are produced during cooking. It also accumulates heat during the initial operating phase allowing, before long, uniform grilling very similar to that obtained using charcoal.

### PRODUCT DIMENSIONS

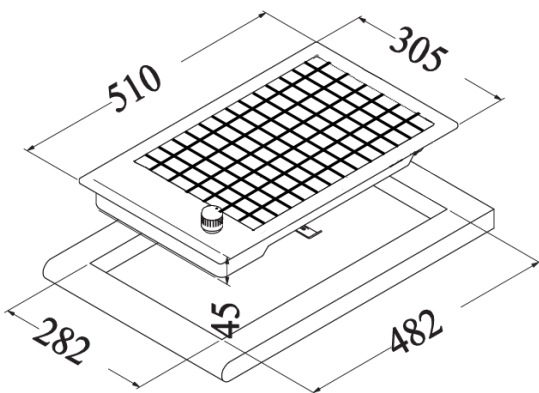

### ELECTRICAL REQUIREMENTS

10 amp dedicated circuit from cooktop to main switchboard.

**VOLTAGE:** 220V-240V

**FREQUENCY:** 50HZ

**TOTAL RATED LOAD:** 2400W

### WEIGHT

5.5kg Gross

### INSTALLATION:

Please refer qualified installer to our product instruction manual.

