

Code EV608SX – 60cm Electric Multifunction Oven



FEATURES:

- 9 multi-functions
 - + Oven Light
 - + Full grill
 - + Conventional
 - + Fan grill
 - + Thermowave fan assisted
 - + Defrost
 - + Bottom element
 - + Top element & grill
 - + Fan forced
- Fully programmed electronic control
- Contained cavity cooling with tangential cooling fan
- Triple glazed removable inner glass
- Removable rack support
- Telescopic runner
- 2 * oven shelves & 1 baking tray
- Enamel oven interior
- Black glass / stainless steel finish

CONVENTIONAL

This conventional cooking method involves the heat emanating evenly from the lower and upper elements into the oven ensures even cooking of the lower and upper side of the food being cooked. This function is perfect for cakes, pastry, baked pasta, lasagne and pizza.

FULL GRILL

Full grill is the perfect option for quick grilling. Toast your favourite meals or finish off the tops of your recipes.

DEFROST

In defrost mode, no heating elements are used. Only the fan is activated to circulate air inside the oven for defrosting. It defrosts food up to 30% faster than traditional methods

THERMOWAVE FAN ASSISTED

This is the position where the heat is coming from the lower and upper heating elements and the heat is circulated into the oven by the fan motor and blades.

OVEN LIGHT

The oven light will automatically turn on once any function is selected, helps to monitor the progress of your cooking.

FAN FORCED COOKING

For the ultimate roast or perfect batch of pastries. The element surrounding the fan delivers even heat for even cooking results, approx. 180°C - 200°C is recommended

FAN GRILL

This function is perfect for fish, chicken Fillets or meat Cutlets. This Combination is exceptional for cooking meats such as poultry, game and roasts, making them crispy on the outside and tender in the middle.

BOTTOM ELEMENT

Great for pizza cooking, the bottom element creates the perfect cooking function for base cooked food.

TOP ELEMENT + GRILL ELEMENT

Grill or toast enough of those favourite after school snacks to feed an army with the top element function.

ELECTRICAL REQUIREMENTS:

This oven can be connected to a 15 AMP wiring connection. Supplied with a 15AMP plug, but can be hardwired if required. For more information, please refer to a qualified electrician.

POWER CONSUMPTION:

220-240v – 50/60Hz - 3.0Kw

OVEN VOLUME CAPACITY:

70 litres (gross) - 65 litres (net)

WEIGHT:

36.8kg (gross) - 33.3kg (net)

CLEANING AND MAINTENANCE

Easy clean AAA grade enamel interior.

Clean stainless steel using only recommended stainless steel cleaning products.

No abrasives, corrosive detergents, bleaches or acids not required for cleaning the oven.

PRODUCT DIMENSIONS

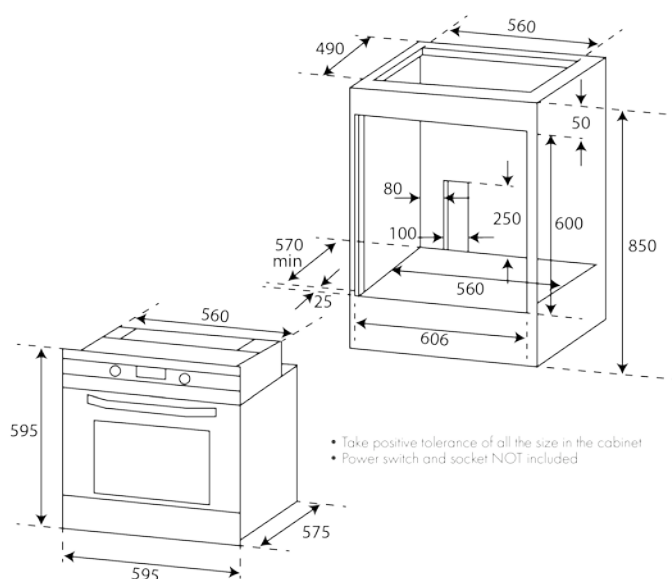

Ovens



bringing european quality to your home