

## Code **ESM8060TSX** – Multifunction Double Oven



### OVEN LIGHT

The oven light will automatically turn on once any function is selected, helps to monitor the progress of your cooking.



### HALF GRILL

Half grilling allows you to toast/brown all your favourite recipes in a smaller area.



### THERMOWAVE FAN ASSISTED

This is the position where the heat is coming from the lower and upper heating elements. This provides very even cooking throughout the middle zones of the oven.



### CONVENTIONAL

This conventional cooking method involves a gentle heat from the lower and upper elements for long slow cooking. This function is perfect for cakes, casseroles and slow roasts.

### FEATURES

- Top oven 4 multi- functions
  - + Oven Light
  - + Conventional
  - + Full Grill
  - + Bottom Element
- Main oven 7 multi-functions
  - + Oven light
  - + Fan Forced
  - + Fan Grill
  - + Bottom Element with Fan
  - + Half Grill
  - + Conventional
  - + Thermo wave Fan Assisted
- + Timer touch Clock Function control
- + Telescopic Rail (x1 set – bottom oven)
- + Cavity Cooling System
- + Triple-glazed removable doors
- + Full inner glass on both doors
- + Made in Italy



### FAN FORCED COOKING

For the ultimate roast or perfect batch of pastries. The element surrounding the fan delivers even heat for even cooking results, approx. 160°C - 180°C is recommended



### FAN GRILL

This function is perfect for grilling foods such as fish, without the need for turning. The door must be left closed whilst grilling and browning will occur from the top element.



### FAN AND BOTTOM ELEMENT

Great for pizza cooking, the fan and bottom element create the perfect cooking function for base cooked food.

### CAVITY COOLING SYSTEM

This oven has a contained cavity cooling system with internal cooling fan. This ensures control knobs are cool and protects surrounding cupboards. The cooling system also provides flow through oven door cooling.

### ELECTRICAL REQUIREMENTS

230-240V / 50HZ – 4250W

**NET WEIGHT: 60.0kg**

**GROSS WEIGHT: 65.0kg**

### OVEN VOLUME CAPACITY:

Main Oven (Bottom ) Gross 74lt – Nett 66lt

Small Oven (Top ) Gross 49lt – Nett 40lt

**INSTALLATION:** Oven requires 20 amps and need a dedicated circuit from the socket to the main switchboard. For all installation please refer qualified technician to our product manual.

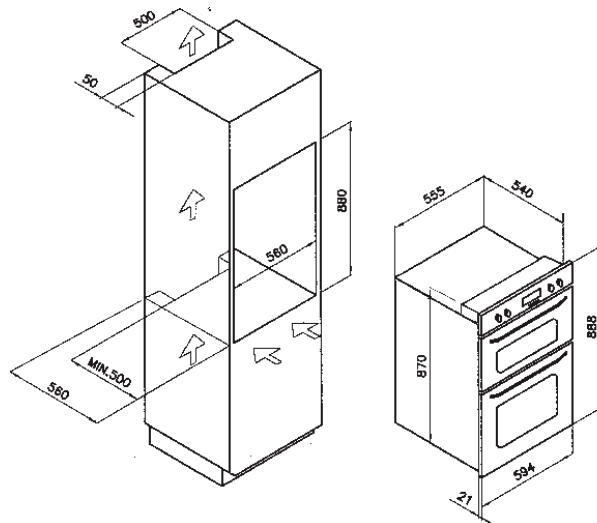

**Double Ovens**



bringing european quality to your home